

Lattice Automotive

Accelerated Time-to-Market with Low-Cost Programmable Logic

The use of programmable logic devices in automotive applications continues to grow each year. Programmable devices are used in many applications, including Engine Control Units, Network Gateways, Camera Systems, Telematics, Digital Radio, X-by-Wire and Display Systems. To keep pace in a highly competitive marketplace, automotive manufacturers must add new and innovative electronic features each model year.

Traditionally, ASICs were used for automotive electronics applications. But, as process technologies change, ASICs are becoming increasingly cost prohibitive, due to skyrocketing NRE charges. As ASIC costs rise, programmable logic devices (CPLDs and FPGAs) are becoming less expensive on a cost per logic element basis.

Lattice's AEC-Q100 qualified programmable logic solutions offer faster time-to-market, greater flexibility and lower cost during both design and manufacturing. Plus, Lattice products offer all the benefits of in-system-programmability (ISP™).

Solutions With Flexibility

- Lattice flexiFLASH™ architecture enables instant-on automotive systems that startup in less than 1ms
- Lattice's ISP™ (In-System Programmable) logic devices can be reconfigured during the design process as well as in the field
- Lattice's innovative ISP products can be easily and inexpensively upgraded after the automobile has shipped
- Lattice's PLDs offer the low-cost and flexibility needed to rapidly design the next generation of automotive electronics systems

Broad Range of Programmable Devices

Lattice offers AEC-Q100 qualified FPGA, CPLD and Programmable Power Managers in automotive temperature grades. Select commercial families are also available in Extended temperature ranges.

Device Family	AEC-Q100 Qualified	Min. Temp.	Max.Temp. (TJ)
LA-XP2	✓	-40°C	+125°C
LA-MachXO™	✓	-40°C	+125°C
LA-ispMACH 4000V	✓	-40°C	+130°C
LA-ispMACH 4000Z	✓	-40°C	+130°C
LA-ispPAC®-POWR1014/A	✓	-40°C	+110°C
LA-LatticeECP3	✓	-40°C	+125°C



Key Features and Benefits

- **AEC-Q100 Qualified**
 - LA-LatticeECP3 SERDES enabled FPGA
 - LA-XP2 “Instant-on” FPGA
 - LA-MachXO Crossover PLD
 - LA-ispMACH 4000V & LA-ispMACH 4000Z CPLD
 - LA-ispPAC-POWR1014/A Programmable Power Manager
 - Supports Customer Specific Requirements (CSR)
 - Version 4 PPAP (Production Part Approval Process) Documentation
- **Lowest Cost for Most Automotive Applications**
 - Lowest price per macrocell/LUT
 - ASIC replacement without NRE charges
 - Lowest cost prototyping
- **System-Level Integration**
 - Reduce part count and board size
 - Advanced, space-saving packages; migration options
 - 256 to 35K LUT4 FPGAs
 - 32 to 256 macrocell CPLDs
 - 32 to 271 I/Os
 - 5, 3.3, 2.5, 1.8, 1.5, 1.2V power supply operation
 - Programmable support for up to 21 I/O standards, including LVDS, SSTL and HSTL
 - Low voltage I/Os are 5V tolerant (LA-ispMACH 4000V/Z)
- **Flexible and Easy-to-Use**
 - Reprogrammable in the field
 - Reduced time-to-market
 - Industry standard third-party design tools
 - IP cores that can be quickly reconfigured
- **Low Power CMOS Operation**
 - Lowest dynamic power consumption
 - Lowest static power consumption (10µA static Icc)
 - Standby power to <100µA (LA-MachXO)

Automotive Solutions

Lattice Programmable Devices for Automotive Apps

The number of electronic systems in automobiles is constantly increasing. New electronics are continuously developed to make driving or riding in a car more enjoyable or to improve the safety features of the car itself. Programmable devices like CPLDs and FPGAs offer automotive systems design flexibility and extended product availability at a very low price.

LA-LatticeECP3

LA-LatticeECP3 FPGA family provides a versatile programmable platform that includes power optimized SERDES, powerful digital-signal processing, high-density on-chip memory, etc.

- Density up to 35K 4-input look up tables
- Low Cost SERDES enabled FPGA
 - PCIe, GbE, SGMII & HDMI
 - 110mW per channel
- DDR3 Memory Support
- Packaging starting at 10x10mm
- 1Gbps I/Os
- 1.3Mb of embedded RAM
- 64 18x18 MULTs

LA-LatticeXP2 Non-Volatile FPGAs

LA-LatticeXP2™ devices combine a Look-up Table (LUT) -based FPGA fabric with Flash non-volatile cells in an architecture referred to as flexiFLASH™ that provides benefits such as instant-on operation, on-chip storage featuring FlashBAK™ embedded block RAM backup.

- flexiFLASH Architecture
- Live Update Technology
- Densities from 5K to 17K 4-input Look-up Tables (LUTs)
- High Performance sysDSP™ Blocks with up to 20 18x18 Multipliers
- Pre-engineered Source Synchronous Interfaces
- Up to 4 sysCLOCK™ PLLs
- Low Cost TQFP, PQFP, and BGA Packaging. Space-saving 8x8mm csBGA.

LA-MachXO Crossover PLD

The LA-MachXO family of non-volatile, infinitely reconfigurable Programmable Logic Devices (PLDs) is well suited for



applications using CPLDs or low-capacity FPGAs.

- Non-Volatile, Infinitely Reconfigurable
- Density from 256 to 2280 LUT4s
- Performance to 4.9ns pin-to-pin
- TransFRTM technology allows easy field upgrades
- Up to 27.6Kbits sysMEMTM Embedded Block RAM
- Flexible I/O buffer
- Up to two analog PLLs per device
- Standby power to <100µA

High Speed and Zero Power CPLDs

Lattice delivers the world's fastest and lowest power CPLDs for automotive applications.

- 7.5ns tPD, 168 MHz Fmax
- 10µA Static ICC (ispMACH 4000Z)
- 5V Tolerant I/O for LVCMOS3.3 interface
- Lowest price per macrocell



Lattice is fully supportive of global industry efforts to phase out the use of lead and other undesirable elements from electronic equipment materials and manufacturing processes.

- Space saving TQFP package options
- Lead-free/RoHS package options
- Easily interfaces with standard 1.8, 2.5, 3.3 and 5V I/O
- Hot-socketing capability
- Non-volatile, IEEE 1532 compliant

ispPAC Power Manager

LA-ispPAC-POWR1014 and LA-ispPAC-POWR1014A devices make board power supply management easy.



- Ruggedized CPLD for sequencing, monitoring and supervisory signal generation
- Programmable precision threshold comparators to monitor up to 10 power supply voltages
- Programmable delay timers plus internal oscillator for flexible timing control
- Programmable high voltage MOSFET driver outputs control supply ramp rate

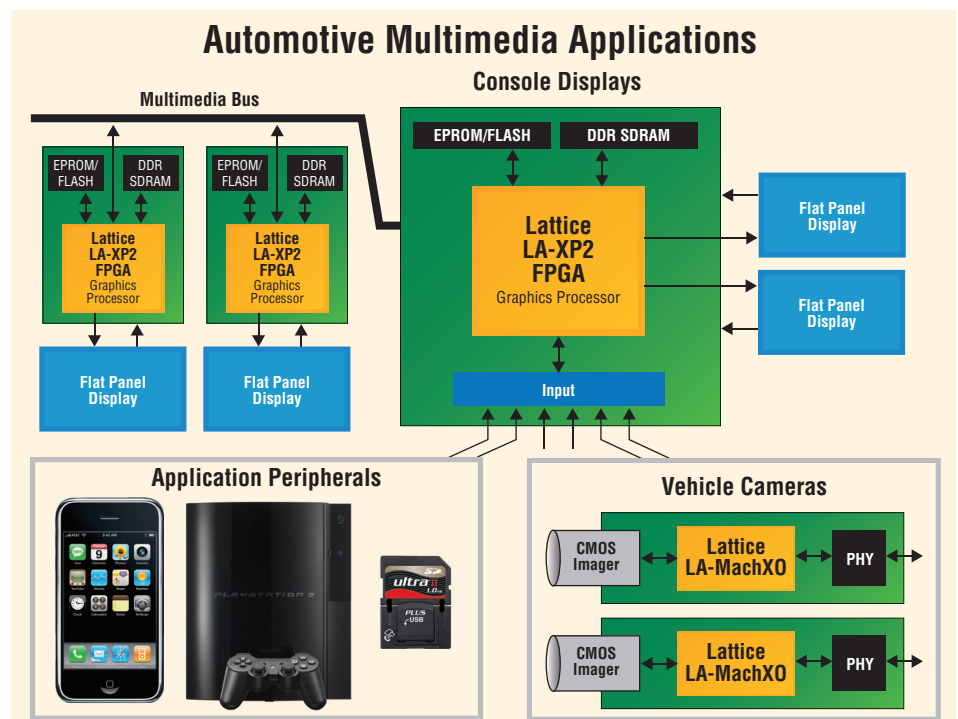

flexiFLASH Overview

flexiFLASH Architecture

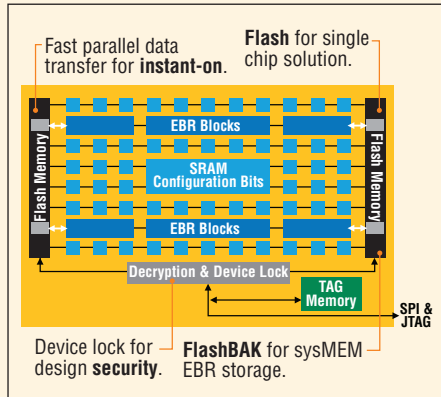

This approach provides a single chip solution, instant-on (1mS), FlashBAK EBR, TAG memory and design security.

FlashBAK Technology

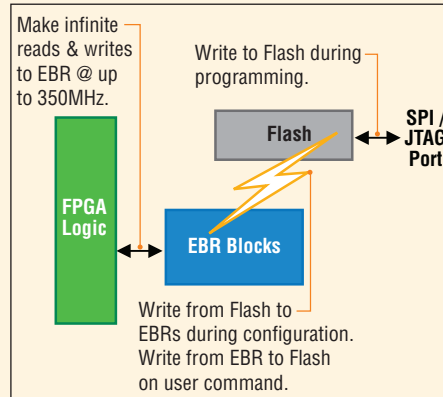

FlashBAK technology allows storage of multiple data types: error codes, data tables, and microprocessor code.

Serial TAG Memory

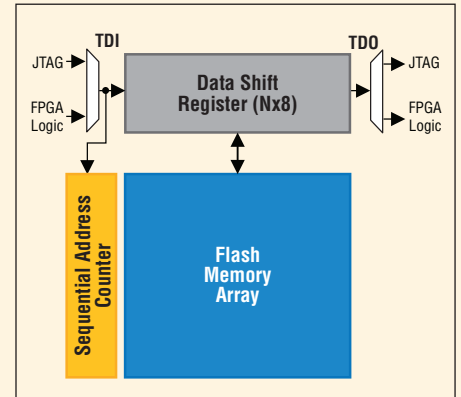

Use Serial TAG Memory to store items such as Board ID, calibration data, and manufacturing information.

Live Update – Flexible, Reliable and Secure Updates

Live Update Technology

Field logic update continues to increase in importance in a wide variety of applications due to the unprecedented flexibility that it provides designers to fix bugs, respond to changing standards, upgrade equipment and add additional services. Lattice's Live Update technology allows logic to be reliably updated in the field without interrupting system operation.



- ✓ Effortless Dealer Updates
- ✓ Add Services and Features
- ✓ Respond to Changing Standards

TransFR Technology

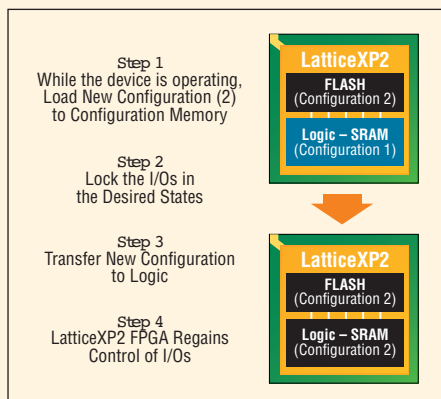

Dual Boot for Reliable Updates

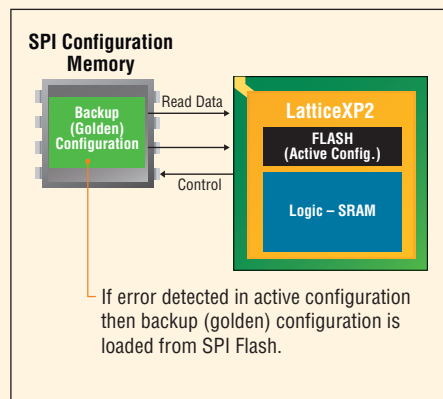

128-Bit AES Bitstream Encryption

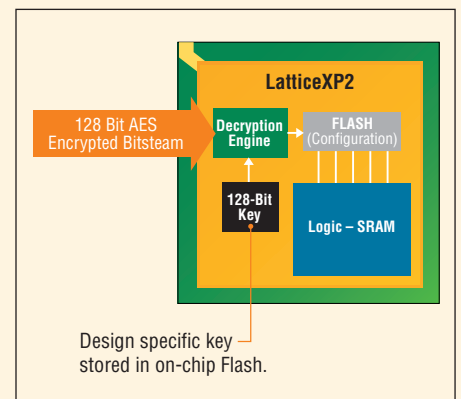

Lattice Automotive AEC-Q100 Qualified and Extended Temperature Products

Device	Family	Density	Description	AEC-Q100 Qualified	Supply Voltage (V _{CC})	5V Tolerant I/O	Package Options
Field Programmable Gate Array (FPGA) Products							
LA-LatticeECP3	ECP3-17	17K LUT	Compact SERDES-based low power FPGAs with powerful digital signal processing and on chip memory	✓	1.2	-	328 csBGA 256 ftBGA 484, 672 fpBGA
	ECP3-35	35K LUT					
LA-LatticeXP2	LAXP2-5	5K LUT	LUT-based FPGA fabric with Flash non-volatile cells provides a single chip solution with benefits such as instant-on operation	✓	1.2	-	100 TQFP ¹ 132 csBGA ^{1,2} 208 PQFP ¹ 256 ftBGA ¹
	LAXP2-8	8K LUT					
	LAXP2-17	17K LUT					
Crossover Logic (CPLD/FPGA) Products							
LA-MachXO	LAMX0256	256 LUT	Instant-on, Flexible LUT Fabric, Performance to 4.9ns Pin-to-Pin, Standby Power to <100µA	✓	3.3/2.5/ 1.8/ 1.5/ 1.2	-	100, 144 TQFP ¹ 256, 324 ftBGA ¹
	LAMX0640	640 LUT					
	LAMX01200	1200 LUT					
	LAMX02280	2280 LUT					
Complex PLDs (Programmable Logic Devices)							
LA-ispMACH 4000V	LA4032V	32 Macrocell	High Speed, Low Power CPLDs	✓	3.3	✓	44, 48, 100, 128, 144 TQFP ¹
	LA4064V	64 Macrocell					
	LA4128V	128 Macrocell					
LA-ispMACH 4000ZC	LA4032ZC	32 Macrocell	Zero StandbyPower, tpd as Low as 7.5ns (168Mhz)	✓	1.8	✓	48, 100, 176 TQFP ¹
	LA4064ZC	64 Macrocell					
	LA4128ZC	128 Macrocell					
ispMACH 4000V	LC4032V	32 Macrocell	High Speed, Low Power CPLDs	-	3.3	✓	44, 48, 100, 128, 144, 176 TQFP
	LC4064V	64 Macrocell					
	LC4128V	128 Macrocell					
	LC4256V	256 Macrocell					
ispMACH 4000ZC	LC4032ZC	32 Macrocell	Zero StandbyPower, tpd as Low as 7.5ns (168Mhz)	-	1.8	✓	48, 100, 176 TQFP
	LC4064ZC	64 Macrocell					
	LC4128ZC	128 Macrocell					
	LC4256ZC	256 Macrocell					
ispPAC Power Manager Family – Programmable Power Supply Sequencing & Monitoring							
LA-ispPAC-POWR1014/A	LA-ispPAC-POWR1014	-	Manages up to 10 Power Suppliers	✓	2.8 to 3.96	✓	48 TQFP ¹
	LA-ispPAC-POWR1014A	-	Manages up to 10 Power Suppliers, Includes ADC Support				
ispPAC-POWR1208	ispPAC-POWR1208	-	Manages up to 12 Power Suppliers	-	2.25 to 5.5	✓	44 TQFP
ispPAC-POWR604	ispPAC-POWR604	-	Manages up to 6 Power Suppliers	-	2.25 to 5.5	✓	44 TQFP

1. Pb-free/RoHS package only.

2. 132 csBGA available for the LAXP2-5 and LAXP2-8 devices only.

ispLEVER Design Tools

Lattice's ispLEVER®, Diamond and PAC Designer software is a comprehensive design environment for the Lattice FPGA architectures. The tools include everything you need for design entry, synthesis, map, place & route, floor-planning, simulation, project management, device programming and more.



Synthesis and simulation tools from industry leaders Synplicity and Aldec are included with the software.

ispLeverCORE™ Intellectual Property

Lattice offers an expanding portfolio of IP cores to support the easy integration of commonly used functions, including:



- Soft Processors
- PCI Express
- DDR SDRAM Controller
- Audio
- SATA
- Compact Flash
- Graphics
- Ethernet

For additional IP cores, go to www.latticesemi.com/ip.

Lattice Quality, Reliability and Commitment

Lattice Semiconductor is committed to providing its customers with the highest quality and most reliable products in the industry. The first major PLD manufacturer to complete ISO9000 registration, Lattice has been registered to the ISO9001 standard since September 1993.

Why make Lattice your automotive PLD supplier of choice? Lattice knows more about PLDs than anyone. We are the inventor of the reprogrammable PLD. Inventor of ISP. Leveraging high-volume process technology for our programmable devices to deliver low-cost and flexibility to your automotive products.

Applications Support

techsupport@latticesemi.com

