



# Certus-NX Hardware Checklist

## Technical Note

FPGA-TN-02151-1.0

July 2020

## Disclaimers

Lattice makes no warranty, representation, or guarantee regarding the accuracy of information contained in this document or the suitability of its products for any particular purpose. All information herein is provided AS IS and with all faults, and all risk associated with such information is entirely with Buyer. Buyer shall not rely on any data and performance specifications or parameters provided herein. Products sold by Lattice have been subject to limited testing and it is the Buyer's responsibility to independently determine the suitability of any products and to test and verify the same. No Lattice products should be used in conjunction with mission- or safety-critical or any other application in which the failure of Lattice's product could create a situation where personal injury, death, severe property or environmental damage may occur. The information provided in this document is proprietary to Lattice Semiconductor, and Lattice reserves the right to make any changes to the information in this document or to any products at any time without notice.

## Contents

|   |    |
|---|----|
| Acronyms in This Document .....                             | 4  |
| 1. Introduction .....                                       | 5  |
| 2. Power Supplies .....                                     | 6  |
| 2.1. Power Noise .....                                      | 7  |
| 2.2. Power Source .....                                     | 7  |
| 3. Certus-NX SERDES and ADC Power Supplies .....            | 8  |
| 3.1. Recommended Power Filtering Groups and Components..... | 8  |
| 3.2. Ferrite Bead Selection Notes.....                      | 9  |
| 3.3. Ground Pins.....                                       | 9  |
| 3.4. Clock Oscillator Supply Filtering.....                 | 9  |
| 3.4.1. Dielectric .....                                     | 9  |
| 3.4.2. Voltage Rating .....                                 | 9  |
| 3.4.3. Size .....   | 9  |
| 3.5. Unused Bank VCCIOx.....                                | 10 |
| 3.6. Unused ADC Blocks .....                                | 10 |
| 3.7. Unused SERDES Blocks .....                             | 10 |
| 4. Power Sequencing .....                                   | 11 |
| 5. Power Estimation.....                                    | 11 |
| 6. Configuration Considerations .....                       | 12 |
| 7. I/O Pin Assignments.....                                 | 14 |
| 8. Clock Inputs .....                                       | 14 |
| 9. Pinout Considerations .....                              | 14 |
| 10. LVDS Pin Assignments.....                               | 14 |
| 11. HSUL and SSTL Pin Assignments .....                     | 15 |
| 12. SERDES Pin Considerations .....                         | 15 |
| 13. Checklist.....  | 16 |
| Technical Support Assistance .....                          | 18 |
| Revision History .....                                      | 19 |

## Figures

|  |    |
|--|----|
| Figure 3.1. Clock Oscillator Bypassing .....                                 | 10 |
| Figure 6.1. Accommodation for Mixed Voltage Across Configuration Banks ..... | 13 |

## Tables

|   |    |
|---|----|
| Table 2.1. Single-Ended I/O Standards .....                               | 6  |
| Table 3.1. Recommended Power Filtering Groups and Components.....         | 8  |
| Table 3.2. Recommended Capacitor Sizes .....                              | 9  |
| Table 6.1. JTAG Pin Recommendations .....                                 | 12 |
| Table 6.2. Pull-up/Pull-down Recommendations for Configuration Pins ..... | 12 |
| Table 6.3. Configuration Pins Needed per Programming Mode.....            | 12 |
| Table 13.1. Hardware Checklist .....                                      | 16 |

## Acronyms in This Document

A list of acronyms used in this document.

| Acronym | Definition  |
|---------|---|
| BGA     | Ball Grid Array                                     |
| CML     | Current-Mode Logic                                  |
| LUT     | Look Up Table                                       |
| LVC MOS | Low-Voltage Complementary Metal Oxide Semiconductor |
| LVDS    | Low-Voltage Differential Signaling                  |

# 1. Introduction

When designing complex hardware using the Certus™-NX device, you must pay special attention to critical hardware configuration requirements. This technical note steps through these critical hardware implementation items relative to the Certus-NX device. The document does not provide detailed step-by-step instructions but gives a high-level summary checklist to assist in the design process.

The device family consists of FPGA densities ranging from 17K to 40K Logic Cells. This technical note assumes that the reader is familiar with the Certus-NX device features as described in [Certus-NX Family Data Sheet \(FPGA-DS-02078\)](#). The data sheet includes the functional specification for the device. Topics covered in the data sheet include but are not limited to the following:

- High-level functional overview
- Pinouts and packaging information
- Signal descriptions
- Device-specific information about peripherals and registers
- Electrical specifications

Refer to [Certus-NX Family Data Sheet \(FPGA-DS-02078\)](#) for details. The critical hardware areas covered in this technical note are:

- Power supplies as they relate to the Certus-NX power supply rails and how to connect them to the PCB and the associated system
- Configuration mode selection for proper power-up behavior
- Device I/O interface and critical signals

**Important:** You should refer to the following documents for detailed recommendations.

- [sysCONFIG Usage Guide for Nexus Platform \(FPGA-TN-02099\)](#)
- [sysI/O Usage Guide for Nexus Platform \(FPGA-TN-02067\)](#)
- [sysCLOCK PLL Design and Usage Guide for Nexus Platform \(FPGA-TN-02095\)](#)
- [Memory Usage Guide for Nexus Platform \(FPGA-TN-02094\)](#)
- [Certus-NX High-Speed I/O Interface \(FPGA-TN-02216\)](#)
- [Thermal Management \(FPGA-TN-02044\)](#)
- [sysDSP Block Usage Guide for Nexus Platform \(FPGA-TN-02096\)](#)
- [Electrical Recommendations for Lattice SERDES \(FPGA-TN-02077\)](#)
- [High-Speed PCB Design Considerations \(FPGA-TN-02148\)](#)
- [Power Decoupling and Bypass Filtering for Programmable Devices \(FPGA-TN-02150\)](#)
- [LatticeSC™ SERDES Jitter \(TN1084\)](#)
- HSPICE SERDES simulation package (available under NDA, contact the license administrator at [lic\\_admin@latticesemi.com](mailto:lic_admin@latticesemi.com))
- [Certus-NX-related pinout information](#) can be found on the Lattice website.

## 2. Power Supplies

The  $V_{CC}$ ,  $V_{CCAUXA}$ , and  $V_{CCIOX}$  power supplies are monitored to determine the Certus-NX internal Power Good condition during power-up. These supplies need to be at a valid and stable level before the device becomes operational. All other supplies are not monitored during power-up, but need to be at valid and stable level before the device configuration is complete and enters into User Mode. Several other supplies are used in conjunction with onboard SERDES Blocks and ADCs on Certus-NX devices.

Table 2.1 describes the power supplies and the appropriate voltage levels for each supply.

**Table 2.1. Single-Ended I/O Standards**

| Supply            | Voltage (Nominal Value)   | Description   |
|-------------------|---|---|
| $V_{CC}$          | 1.0 V   | FPGA core power supply. Required for Power Good condition.  |
| $V_{CCAUXA}$      | 1.8 V   | Auxiliary Supply Voltage for Core logic. Required for Power Good condition.   |
| $V_{CCAUX}$       | 1.8 V   | Auxiliary power supply voltage for internal analog circuitry Banks 0, 1, 2, 6, and 7.   |
| $V_{CCAUXH[5:3]}$ | 1.8 V   | Auxiliary power supply voltage for internal analog circuitry Banks 3, 4, and 5.   |
| $V_{CCIO[7:0]}$   | Banks 0, 1, 2, 6, 7:<br>1.2 V, 1.5 V, 1.8 V, 2.5 V, 3.3 V.<br>Banks 3, 4, 5:<br>1.0 V, 1.2 V, 1.35 V, 1.5 V, 1.8 V. | Bank I/O Driver Supply Voltage. Each bank has its own $V_{CCIO}$ supply: $V_{CCIO0}$ and $V_{CCIO1}$ are used in conjunction with pins dedicated and shared with device configuration, and are required for Power Good condition. |
| $V_{CCADC18}$     | 1.8 V   | ADC Block power supply. Should be isolated from excessive noise.  |
| $ADC\_REFP[1:0]$  | 1.2 V to 1.8 V Typical  | ADC External Reference. Should be isolated from excessive noise and have high accuracy (< 0.1%).  |
| $V_{CCSD0}$       | 1.0 V   | SERDES Block Core power supply voltage. Should be isolated from excessive noise.  |
| $V_{CCPLSD0}$     | 1.8 V   | SERDES Block PLL power supply voltage. Should be isolated from excessive noise.   |
| $V_{CCAUXSD}$     | 1.8 V   | SERDES Block Auxiliary power supply voltage. Should be isolated from excessive noise.   |

The Certus-NX FPGA device has a power-on-reset state machine that depends on several of the power supplies. These supplies should come up monotonically. Initialization of the device does not proceed until all monitored power supplies have reached their minimum operating voltages.

## 2.1. Power Noise

The power rail voltages of the FPGA allow for a worst-case normal operating tolerance of  $\pm 5\%$  of these voltages. The 5% tolerance includes any noises.

## 2.2. Power Source

It is recommended that the designed voltage regulators are accurate to within 3% of the optimum voltage to allow power noise design margin.

When calculating the voltage regulator total tolerance, include:

- Regulator voltage reference tolerance
- Regulator line tolerance
- Regulator load tolerance
- Tolerances of any resistors connected to regulator's feedback pin which sets regulator's output voltage
- Expected voltage drops due to power filtering ferrite bead's ESR \* expected current draw
- Expected voltage drops due to current measuring resistor's ESR \* expected current draw

With 3% tolerance allocated to the voltage source, the design has a remaining 2% tolerance for noise and layout related issues. The 1.0 V rail is especially sensitive to noise as every 10 mV is 1% of the rail voltage. For SERDES differential power rails, it is recommended to target a maximum 1% peak noise. For PLLs, target less than 0.25% peak noise.

### 3. Certus-NX SERDES and ADC Power Supplies

There are supplies dedicated to the operation of the Certus-NX SERDES Blocks and ADCs. These supplies are also paired with dedicated ground pins. Providing a quiet supply is critical for these blocks. Supplies should be decoupled with adequate power filters. Bypass capacitors must be located close to the device package pins.

For the best jitter performance, careful pin assignment keeps noisy I/O pins away from sensitive functional pins. The leading causes of PCB related crosstalk to sensitive blocks is related to FPGA outputs located in close proximity to the sensitive power supplies. These supplies require cautious board layout to ensure noise immunity to the switching noise generated by FPGA outputs. Guidelines are provided to build quiet filtered supplies for the analog supplies, however, robust PCB layout is required to ensure that noise does not infiltrate into these analog supplies.

#### 3.1. Recommended Power Filtering Groups and Components

**Table 3.1. Recommended Power Filtering Groups and Components**

| Power Input  | Recommended Filter  | Notes  |
|--|---|--|
| V <sub>CC</sub>  | 10 $\mu$ F x 3 + 100 nF per pin   | Core logic.<br>1.0 V   |
| V <sub>CCAUXA</sub>  | 120 $\Omega$ FB + 10 $\mu$ F + 100 nF per pin   | Auxiliary power supply pin for Core logic.<br>1.8 V  |
| V <sub>CCAUX</sub> and V <sub>CCAUXH[5:3]</sub><br>Combined Together | 120 $\Omega$ FB + 10 $\mu$ F x 2 + 100 nF per pin   | Auxiliary power supply pin for internal analog circuitry<br>V <sub>CCAUX</sub> Banks 0, 1, 2, 6, 7.<br>V <sub>CCAUXH[5:3]</sub> Banks 3, 4, 5.<br>1.8 V  |
| V <sub>CCIO[7:0]</sub>   | 10 $\mu$ F + 100 nF per pin   | Bank I/O.<br>Unused banks can replace the 10 $\mu$ F with a 1.0 $\mu$ F.<br>For banks with lots of outputs or large capacitive loading replace the 10 $\mu$ F with a 22 $\mu$ F (or add one additional 10 $\mu$ F).<br>Banks 0, 1, 2, 6, 7 = 1.2 V, 1.5 V, 1.8 V, 2.5 V, 3.3 V.<br>Banks 3, 4, 5 = 1.0 V, 1.2 V, 1.35 V, 1.5 V, 1.8 V. |
| V <sub>CCADC18</sub>   | 220 $\Omega$ or 120 $\Omega$ FB + 10 $\mu$ F + 100 nF per pin   | ADC Block.<br>If ADC Block not used, leave open.<br>1.8 V  |
| ADC_REFP[1:0]  | 100 nF per pin  | ADC Block External Reference.<br>Must have very low noise and high accuracy (< 0.1%).<br>Voltage source/regulator should be filtered by 220 $\Omega$ or 120 $\Omega$ FB + 1 $\mu$ F<br>If ADC Block not used, leave open.<br>1.2 V to 1.8 V Typical  |
| V <sub>CCSD0</sub>   | 120 $\Omega$ FB + 10 $\mu$ F + 100 nF per pin   | SERDES Block Core.<br>If SERDES Block not used, leave open.<br>1.0 V   |
| V <sub>CCPLSD0</sub>   | 220 $\Omega$ or 120 $\Omega$ FB + 2.2 $\mu$ F + 100 nF per pin<br>IMPORTANT: Connect capacitor grounds only to FPGA pin HSREFRET_P/Nx | SERDES Block PLL.<br>If SERDES Block not used, leave open.<br>Bypass capacitor grounds go only to HSREFRET_P/Nx<br>1.8 V   |
| V <sub>CCAUXSD</sub>   | 120 $\Omega$ FB + 10 $\mu$ F + 100 nF per pin   | SERDES Block Auxiliary.<br>If SERDES Block not used, leave open.<br>1.8 V  |



### 3.2. Ferrite Bead Selection Notes

- Most designs work well using ferrite beads between 120 Ω @100 MHz and 240 Ω @100 MHz.
- Ferrite bead induced noise voltage from ESR \* CURRENT should be < 1% of rail voltage for non-analog rails and < 0.25% for sensitive rails.
- Non-PLL rails should use ferrite beads with ESR between 0.025 Ω and 0.10 Ω depending on current load.
- PLL rails are low current which allow ferrite beads with ESR ≤ 0.3 Ω.
- Small package size ferrite beads have higher ESR than large package size ferrite beads of same impedance.
- High impedance ferrite beads have higher ESR than low impedance ferrite beads in the same package size.

### 3.3. Ground Pins

- All ground pins need to be connected to the board’s ground plane.
- VSSSD0 and VSSADC pins are sensitive to noise and should be isolated from fast switching high current pathways on the ground plane. Ground plane islands can be used to help isolate sensitive grounds from noisy ground areas. The ground plane islands must connect at only one location to the main ground plane. Connection locations should be at least 2 mm wide. Only signals in the same domain as the ground plane island should be referenced to that island.
- SDO\_REFRET — Input SERDES Reference Return Input. This pin should be AC coupled (bypassed) to the V<sub>CCPLLSD0</sub> supply.

### 3.4. Clock Oscillator Supply Filtering

When providing an external reference clock to the FPGA from, for example, a single-ended or differential clock oscillator, proper power supply isolation and decoupling of the clock oscillator is recommended. A typical bypassing circuit is shown below in [Figure 3.1](#).

When specifying components, choose good quality ceramic capacitors in small packages, and place them as close to the clock oscillator supply pins as practically possible. *Good quality* capacitors for bypassing generally meet the following requirements:

#### 3.4.1. Dielectric

Use dielectrics such as X5R, X7R and similar which have good capacitance tolerance (≤ ±20%) over temperature range. Avoid Y5V, Z5U and similarly poor capacitance controlled dielectrics.

#### 3.4.2. Voltage Rating

Capacitor working capacitance decreases non-linearly with higher voltage bias. To maintain capacitance, the capacitor voltage rating should target at least 80% higher than the voltage rail (maximum). Example: 3.3 V rail bypass capacitors should use the commonly available 6.3 V rating as a minimum.

#### 3.4.3. Size

Smaller body capacitors have lower inductance, work to higher frequencies, and improve board layout. For a given voltage rating, smaller body capacitors tend to cost more than larger body capacitors. Optimizing between market pricing and size related inductance, the following capacitor sizes are recommended:

**Table 3.2. Recommended Capacitor Sizes**

| Capacitance    | Size Preferred | Size Next Best |
|----------------|----------------|----------------|
| 0.1 uF         | 0201           | 0402           |
| 1.0 uF, 2.2 uF | 0402           | 0603           |
| 4.7 uF         | 0603           | 0402           |
| 10 uF          | 0603           | 0805           |
| 22 uF          | 0805           | 1206           |

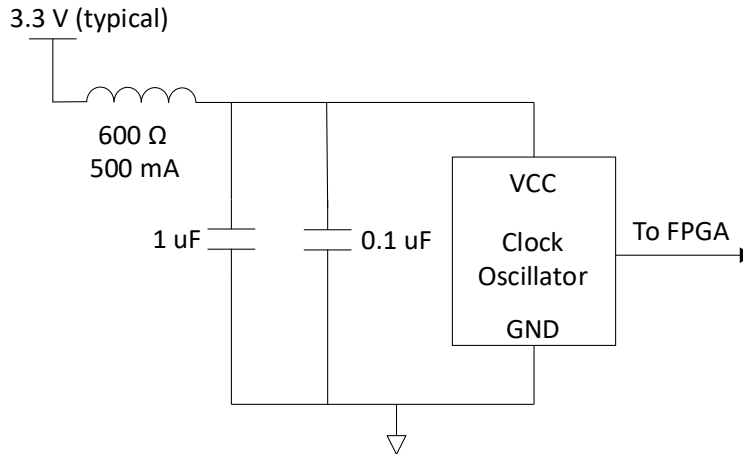

Figure 3.1. Clock Oscillator Bypassing

### 3.5. Unused Bank VCCIOx

Connect unused  $V_{CCIO5}$  to a power rail, Do not leave them open.

### 3.6. Unused ADC Blocks

Connect  $V_{SSADC}$  pins to board ground. Leave  $V_{CCADC18}$  and ADC I/O floating (not connected).

### 3.7. Unused SERDES Blocks

Connect  $V_{SSSD}$  pins to board ground. Leave  $V_{CCSD0}$ ,  $V_{CCPLSD0}$ ,  $V_{CCAUX}$  and SERDES I/O floating (not connected).

## 4. Power Sequencing

There is no power up sequence required for the Certus-NX device.

## 5. Power Estimation

Once the Certus-NX device density, package, and logic implementation is decided, power estimation for the system environment should be determined based on the Power Calculator provided as part of the Lattice Radiant® design tool. When estimating power, the designer should keep two goals in mind:

- Power supply budgeting should be based on the maximum of the power-up in-rush current, configuration current and maximum DC and AC current for the given system environmental conditions.
- The ability for the system environment and Certus-NX device packaging to be able to support the specified maximum operating junction temperature. By determining these two criteria, the Certus-NX device power requirements are taken into consideration early in the design phase.

## 6. Configuration Considerations

PCB layout design and breakout suggestions are outlined in [PCB Layout Recommendations for BGA Packages \(FPGA-TN-02024\)](#). WLCSP packages are similar to other BGA (ball grid array) packages with regard to the PCBs the packages are to be mounted on. For application-specific assembly guidance, consult the design guidelines of the assembly service provider.

The Certus-NX device includes provisions to configure the FPGA via the JTAG interface or several modes utilizing the sysCONFIG port. The JTAG port includes a 4-pin interface. The interface requires the following PCB considerations.

**Table 6.1. JTAG Pin Recommendations**

| JTAG Pin | PCB Recommendation                   |
|----------|--------------------------------------|
| TDI/SI   | 4.7 kΩ pull-up to V <sub>CCIO1</sub> |
| TMS/SCSN | 4.7 kΩ pull-up to V <sub>CCIO1</sub> |
| TDO/SO   | 4.7 kΩ pull-up to V <sub>CCIO1</sub> |
| TCK/SCLK | 2.2 kΩ pull-down to GND              |

Every PCB is recommended to have easy access to FPGA JTAG pins, even if the primary configuration interface is not using the JTAG port. This JTAG port enables debugging in the final system. For best results, route the TCK, TMS, TDI, and TDO signals to a common test header along with V<sub>CCIO1</sub> and ground.

External resistors are necessary if the configuration signals are used to handshake with other devices. Recommended pull-up resistors to the appropriate bank V<sub>CCIO</sub> and pull-down to board ground should be used on the following pins. External pull-resistors are not necessary on individual configuration pins when the signal pin is not persisted.

**Table 6.2. Pull-up/Pull-down Recommendations for Configuration Pins**

| Pin      | PCB Connection  |
|----------|---|
| PROGRAMN | 4.7 kΩ pull-up to V <sub>CCIO0</sub>  |
| INITN    | 4.7 kΩ pull-up to V <sub>CCIO0</sub>  |
| DONE     | 4.7 kΩ pull-up to V <sub>CCIO0</sub>  |
| MCLK     | 1.0 kΩ to GND   |
| MCSN     | 4.7 kΩ pull-up to V <sub>CCIO0</sub>  |
| JTAG_EN  | 4.7 kΩ pull-down to GND (JTAG port disabled)<br>or 1.0 kΩ pull-up to V <sub>CCIO1</sub> (JTAG port enabled) |
| TMS/SCSN | 4.7 kΩ pull-up to V <sub>CCIO1</sub>  |
| SCL/SDA  | 1.0 kΩ to 4.7 kΩ pull-up to V <sub>CCIO1</sub>  |

**Table 6.3. Configuration Pins Needed per Programming Mode**

| Configuration Mode   | Bank | Enablement      | Clock |        | Bus Size | Pins                           |
|----------------------|------|-----------------|-------|--------|----------|--------------------------------|
|                      |      |                 | Pin   | I/O    |          |                                |
| MSPI                 | 0    | (Default)       | MCLK  | Output | 1        | MCLK, MCSN, MOSI, MISO         |
|                      |      |                 |       |        | 2        | MCLK, MCSN, MD0, MD1           |
|                      |      |                 |       |        | 4        | MCLK, MCSN, MD0, MD1, MD2, MD3 |
| JTAG                 | 1    | JTAG_EN pin*    | TCLK  | Input  | 1        | TCK, TMS, TDI, TDO             |
| SSPI                 | 1    | Activation key* | SCLK  | Input  | 1        | SCLK, SCSN, SI, SO             |
|                      |      |                 |       |        | 2        | SCLK, SCSN, SD0, SD1           |
|                      |      |                 |       |        | 4        | SCLK, SCSN, SD0, SD1, SD2, SD3 |
| I <sup>2</sup> C/I3C | 1    | Activation key  | SCL   | Input  | 1        | SCL, SDA                       |

**\*Note:** JTAG and SSPI ports share pins. When JTAG\_EN is asserted, the JTAG port takes precedence over SSPI.

Some architectures require Bank 0 and Bank 1 to have different bank voltages. One such architecture is illustrated in [Figure 6.1](#). In the event a control signal, such as PROGRAMN, originates in one voltage domain but is terminated in another, a voltage translating device or circuit must be implemented to reduce excess current leakage or possible device damage. [Figure 6.1](#) shows a voltage translator utilized for PROGRAMN, allowing a 3.3 V driver to safely and efficiently drive the 1.8 V bank 0 input buffer.

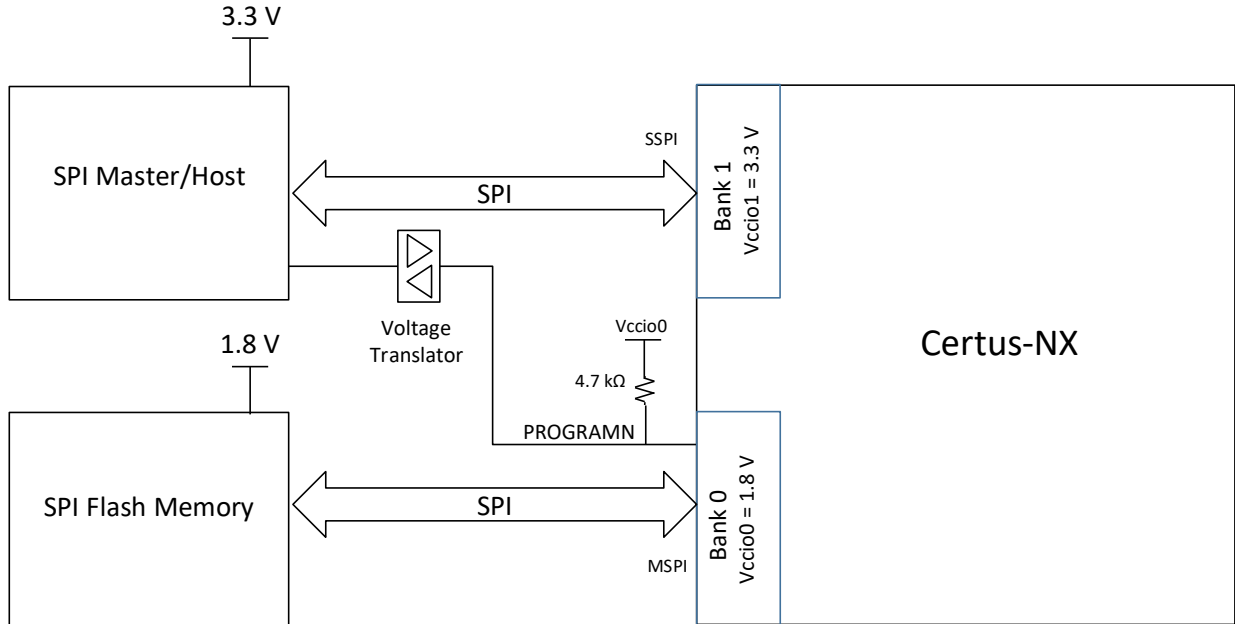

**Figure 6.1. Accommodation for Mixed Voltage Across Configuration Banks**

## 7. I/O Pin Assignments

Assembly and rework parameters for WLCSP packages are similar to other BGA packages. Refer to [Solder Reflow Guide for Surface Mount Devices \(FPGA-TN-02041\)](#), which outlines the reflow parameters for all the various package styles offered, including WLCSP.

The VCCPLSD0 and VCCAUXSD provide *quiet* supplies for the SERDES blocks. For the best jitter performance, careful pin assignment keeps *noisy* I/O pins away from *sensitive* pins. The leading causes of PCB related SERDES crosstalk is related to FPGA outputs located in close proximity to the sensitive SERDES power supplies. These supplies require cautious board layout to insure noise immunity to the switching noise generated by FPGA outputs. Guidelines are provided to build quiet filtered supplies, however, robust PCB layout is required to insure that noise does not infiltrate into these analog supplies.

Although coupling has been reduced in the device packages of Certus-NX devices where little crosstalk is generated, the PCB board can cause significant noise injection from any I/O pin adjacent to SERDES data, reference clock, and power pins as well as other critical I/O pins such as clock signals. [Electrical Recommendations for Lattice SERDES \(FPGA-TN-02077\)](#) provides detailed guidelines for optimizing the hardware to reduce the likelihood of crosstalk to the analog supplies. PCB traces running in parallel for long distances need careful analysis. Simulate any suspicious traces using a PCB crosstalk simulation tool to determine if they cause problems.

It is common practice for designers to select pinouts for their system very early in the design cycle. For the FPGA designer, this requires a detailed knowledge of the targeted FPGA device. Designers often use a spreadsheet program to initially capture the list of the design I/O. Lattice Semiconductor provides detailed pinout information that can be downloaded from the Lattice Semiconductor website in .csv format for designers to use as a resource to create pinout information. For example, by navigating to the pinout.csv file, you can gather the pinout details for all the different package offerings of the device in the family, including I/O banking, differential pairing, Dual Function of the pins, and input and output details.

## 8. Clock Inputs

The Certus-NX device provides certain pins for use as clock inputs in each I/O bank. These pins are shared and can alternately be used for General Purpose I/O.

When these pins are used for clocking purpose, you need to pay attention to minimize signal noise on these pins. Refer to [Certus-NX High-Speed I/O Interface \(FPGA-TN-02216\)](#).

These shared clock input pins can be found under the Dual Function column of the pinlist csv file.

## 9. Pinout Considerations

The Certus-NX device supports many applications with high-speed interfaces. These include various rule-based pinouts that need to be understood prior to implementation of the PCB design on these high-speed interfaces. The pinout selection must be completed with an understanding of the interface building blocks implemented in the FPGA fabric. These include IOLOGIC blocks such as DDR, clock resource connectivity, and PLL and DLL usage. Refer to [Certus-NX High-Speed I/O Interface \(FPGA-TN-02216\)](#) for rules pertaining to these interface types.

## 10. LVDS Pin Assignments

True LVDS inputs and outputs are available on I/O pins on the bottom side of the devices. Top, left, and right side I/O banks do not support True LVDS standard, but can support emulated LVDS outputs. True LVDS input pairing on bottom banks can be found under the High-Speed column in the pinlist csv file.

Emulated LVDS output are available on pairs around all banks, but this requires external termination resistors. This is described in [sys/I/O Usage Guide for Nexus Platform \(FPGA-TN-02067\)](#).

## 11. HSUL and SSTL Pin Assignments

The HSUL and SSTL interfaces are referenced I/O standards require an external reference voltage. HSUL and SSTL are supported on the device bottom banks only. The  $V_{REF}$  pin(s) should get high priority when assigning pins on the PCB. These pins can be found in the Dual Function column with  $V_{REF}$  label. Each bank includes a separate  $V_{REF}$  voltage.  $V_{REF}$  sets the threshold for the referenced input buffers. Each I/O is individually configurable based on the bank supply and reference voltages.

## 12. SERDES Pin Considerations

High-speed signaling requires careful PCB design. Maintaining good transmission line characteristics is a requirement. A continuous ground reference should be maintained with high-speed routing. This includes tightly matched differential routing with very few discontinuities. Refer to [High-Speed PCB Design Considerations \(FPGA-TN-02148\)](#) for suggested methods and guidance.

## 13. Checklist

**Table 13.1. Hardware Checklist**

|          | Item  | OK | NA |
|----------|---|----|----|
| <b>1</b> | <b>FPGA Power Supplies</b>  |    |    |
| 1.1      | Core Supplies   |    |    |
| 1.1.1    | $V_{CC}$ core @ 1.0 V $\pm 5\%$   |    |    |
| 1.1.2    | Use a PCB plane for $V_{CC}$ core with proper decoupling  |    |    |
| 1.1.3    | $V_{CC}$ core sized to meet power requirement calculation from software   |    |    |
| 1.1.4    | $V_{CCAUX}$ and $V_{CCAUXH3/H4/H5}$ @ 1.8 V $-3\%/+5\%$   |    |    |
| 1.1.5    | $V_{CCAUXA}$ @ 1.8 V $-3\%/+5\%$  |    |    |
| 1.1.6    | $V_{CCAUXA}$ <i>quiet and isolated</i>  |    |    |
| 1.1.7    | $V_{CCAUXA}$ pins should be ganged together and a solid PCB plane is recommended. This plane should not have adjacent non-SERDES signals passing above or below. It should also be isolated from the $V_{CC}$ core power plane. |    |    |
| 1.2      | I/O Supplies  |    |    |
| 1.2.1    | All <i>Wide Range</i> $V_{CCIO}$ (Banks 0,1,2,6,7) are between 1.2 V to 3.3 V   |    |    |
| 1.2.2    | All <i>High Performance</i> (Bank 3,4,5) $V_{CCIO}$ are between 1.0 V to 1.8 V  |    |    |
| 1.2.3    | All Configuration $V_{CCIO}$ (Banks 0,1), when used with configuration interfaces (for example, memory devices), need to match specifications.  |    |    |
| 1.2.4    | $V_{CCIO[7:2]}$ used based on user design   |    |    |
| 1.3      | ADC power supplies  |    |    |
| 1.3.1    | $V_{CCADC18}$ is 1.8 V $+5\%$   |    |    |
| 1.3.2    | $V_{CCADC18}$ <i>quiet and isolated</i>   |    |    |
| 1.4      | SERDES Power Supplies   |    |    |
| 1.4.1    | $V_{CCSD0}$ are at 1.0 V $\pm 5\%$  |    |    |
| 1.4.2    | $V_{CCPLSD0}$ and $V_{CCAUXSD}$ are 1.8 V $+5\%$  |    |    |
| 1.4.3    | $V_{CCPLSD0}$ and $V_{CCAUXSD}$ <i>quiet and isolated</i> from each other and other 1.8 V supplies  |    |    |
| <b>2</b> | <b>JTAG</b>   |    |    |
| 2.1      | Pull-up or Pull-down on JTAG_EN, per <a href="#">Table 6.2</a> .  |    |    |
| 2.2      | Keep JTAG_EN accessible on PCB to recover JTAG port, especially during development.   |    |    |
| 2.3      | Keep JTAG port pins accessible on PCB, especially during development  |    |    |
| 2.4      | Pull-down on TCK per <a href="#">Table 6.1</a> .  |    |    |
| 2.5      | Pull-up on TMS per <a href="#">Table 6.1</a> .  |    |    |
| <b>3</b> | <b>Configuration</b>  |    |    |
| 3.1      | Pull-ups or pull-downs on persisted configuration specific pins per <a href="#">Table 6.1</a> and <a href="#">Table 6.2</a>   |    |    |
| 3.2      | $V_{CCIO0}$ , $V_{CCIO1}$ bank voltage matches sysCONFIG peripheral devices such as SPI Flash   |    |    |
| <b>4</b> | <b>Special Pin Assignments</b>  |    |    |
| 4.1      | VREF assignments followed for single-ended SSTL inputs  |    |    |
| 4.2      | Properly decouple the VREF source   |    |    |



|          | Item  | OK | NA |
|----------|---|----|----|
| <b>5</b> | <b>Critical Pinout Selection</b>  |    |    |
| 5.1      | Pinout is chosen to address FPGA resource connections to I/O logic and clock resources per <a href="#">Certus-NX High-Speed I/O Interface (FPGA-TN-02216)</a> .   |    |    |
| 5.2      | Shared general purpose I/O are used as inputs for FPGA PLL and Clock inputs.  |    |    |
| <b>6</b> | <b>LPDDR3 and DDR3 Interface Requirements</b>   |    |    |
| 6.1      | DQ, DM, and DQS signals should be routed in a data group and should have similar routing and matched via counts. Using more than three vias is not recommended in the route between the FPGA controller and memory device.  |    |    |
| 6.2      | Maintain trace length matching to a maximum of $\pm 50$ mil between any DQ/DM and its associated DQS strobe within a DQ group. Use careful serpentine routing to meet this requirement.   |    |    |
| 6.3      | All data groups must reference a ground plane within the stack-up.  |    |    |
| 6.4      | DDR trace reference must be solid without slots or breaks. It should be continuous between the FPGA and the memory.   |    |    |
| 6.5      | Provide a separation of 3 W spacing between a data group and any other unrelated signals to avoid crosstalk issues. Use a minimum of 2 W spacing between all DDR traces excluding differential CK and DQS signals. (W is the minimum width of the signal trace allowed) |    |    |
| 6.6      | Assigned FPGA I/O within a data group can be swapped to allow clean layout. Do not swap DQS assignments.  |    |    |
| 6.7      | Differential pair of DQS to DQS_N trace lengths should be matched at $\pm 10$ mil.  |    |    |
| 6.8      | Resistor terminations (DQ) placed in a fly-by fashion at the FPGA is highly recommended. Stub fashion terminations, if used, should not include a stub longer than 600 mil.   |    |    |
| 6.9      | LDQS/LDQS_N and UDQS/UDQS_N trace lengths should be matched within $\pm 100$ mil.   |    |    |
| 6.10     | Address/control signals and the associated CK and CK_N differential FPGA clock should be routed with a control trace matching $\pm 100$ mil.  |    |    |
| 6.11     | CK to CK_N trace lengths must be matched to within $\pm 10$ mil.  |    |    |
| 6.12     | Address and control signals can be referenced to a power plane if a ground plane is not available. Ground reference is preferred.   |    |    |
| 6.13     | Address and control signals should be kept on a different routing layer from DQ, DQS, and DM to isolate crosstalk between the signals.  |    |    |
| 6.14     | Differential terminations used by the CLK/CLKN pair must be located as close as possible to the memory.   |    |    |
| 6.15     | Address and control terminations placed after the memory component using a fly-by technique are highly recommended. Stub fashion terminations, if used, should not include a stub longer than 600 mils.   |    |    |
| <b>7</b> | <b>SERDES</b>   |    |    |
| 7.1      | Dedicated reference clock input from clock source meets the DC and AC requirements  |    |    |
| 7.2      | External AC coupling caps may be required for compatibility to common-mode levels   |    |    |
| 7.3      | Ref clock termination resistors may be needed for compatible signaling levels   |    |    |
| 7.4      | Maintain good high-speed transmission line routing  |    |    |
| 7.5      | Continuous ground reference plane to serial channels  |    |    |
| 7.6      | Tightly length matched differential traces, $\pm 4$ mils maximum  |    |    |
| 7.7      | Do not pass other signals on the PCB above or below the high-speed SERDES without isolation.  |    |    |
| 7.8      | Keep non-SERDES signal traces from passing above or below the VCCPLSD0 and VCCAUXSD power plane without isolation.  |    |    |

## Technical Support Assistance

Submit a technical support case through [www.latticesemi.com/techsupport](http://www.latticesemi.com/techsupport).

## Revision History

### Revision 1.0, July 2020

| Section | Change Summary   |
|---------|------------------|
| All     | Initial release. |



[www.latticesemi.com](http://www.latticesemi.com)