

Pitfalls to Avoid in Selection of Reset Generators and Voltage Supervisors

Components require multiple lower-power supply voltages to operate

Market pressures are constantly forcing engineers to enhance product features while reducing the product's cost and form factor. This challenge typically is met with the use of ICs and microprocessors with a higher degree of integration.

By Srirama Chandra, Product Marketing Manager,

In-System Programmable Mixed Signal Products, Lattice Semiconductor Corp.

These supply voltages are generated by on-board power supplies (or DC-DC Converters) operating from the input supply. In order to provide the same level of reliability as simple single supply boards, all of the supplies on the board must be monitored. A new generation of voltage supervisors and reset generators facilitate the monitoring of these multiple power supplies.

What are Reset Generators and Voltage Supervisors?

Most microprocessors provide a "Reset" pin to enable the external hardware to begin program execution from a fixed memory location. This pin should be driven by an external IC, called a Reset Generator, which activates the reset signal for a brief period of time after all the supplies powering the processor are turned on. Reset generators also activate the reset signal when an external input, such as a manual reset input, is activated.

So, what happens when the board supply is turned off, or when one of the on-board supplies develops a fault?

When the input power is turned off,

all on-board supplies begin to turn off and their output voltages start to drop. On the other hand, when the supply develops a fault, its output voltage can drop below a specified level or increase to dangerous levels. While the supply voltages are dropping, processors can execute instructions incorrectly and jump to unintended memory locations. Consequently, the processor can over-

write its Flash memory contents, rendering the system inoperable.

To prevent such a system failure, a voltage supervisor IC is used. The supervisor IC monitors supply voltages and interrupts the on-board processor when any supply becomes faulty. The processor can then safely abort its current activity or save its mission critical

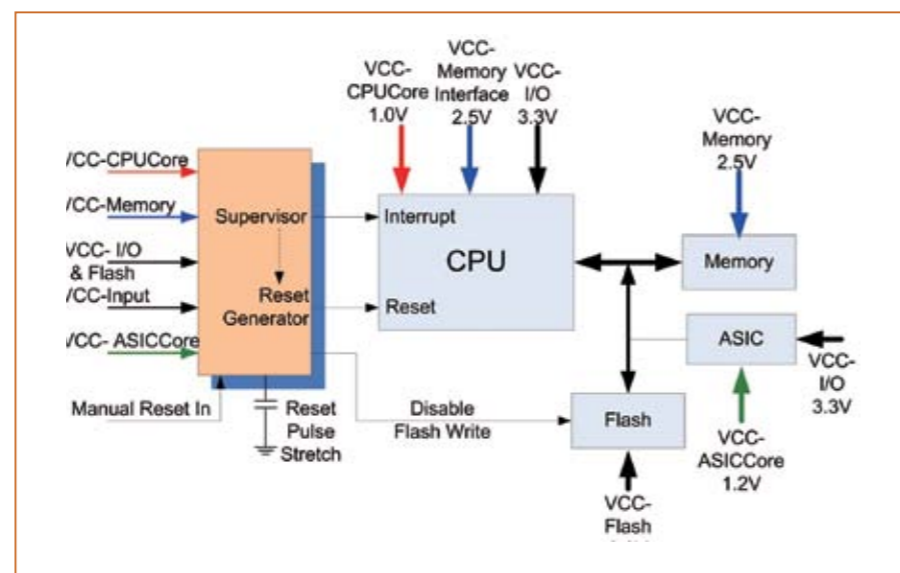

Figure 1: Block diagram of microprocessor board.

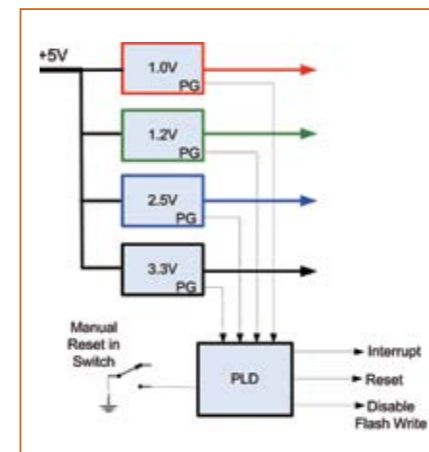

Figure 2: Voltage monitoring with a PLD.

information. After that, the reset generator can hold the processor in reset condition until all the supplies are turned off.

Figure 1 is a block diagram of a simple microprocessor board. The microprocessor is powered by its core voltage and a couple of I/O supplies. The memory, ASIC and Flash memories are shown with their supplies.

Voltage supervisor and reset generator operation

The Reset Generator waits for all supplies to stabilize and then releases the reset signal of the CPU after a reset pulse stretch period (determined by the capacitor). Then the Flash memory write feature is enabled. If for some reason any of the on-board supplies becomes faulty during power on, the reset for the processor is not released, preventing the corruption of Flash memory.

When all the power supplies are turned on, the supervisor monitors all supply voltages (including the input supply). The supervisor generates an interrupt to the processor if any of the supplies become faulty and, after a brief period, activates the CPU Reset and disables the Flash write signal.

The effectiveness of a supervisor depends on its voltage monitoring accuracy and the speed of voltage fault detection.

Selecting the voltage monitoring threshold for a supervisor

In Figure 1, the CPU Core voltage

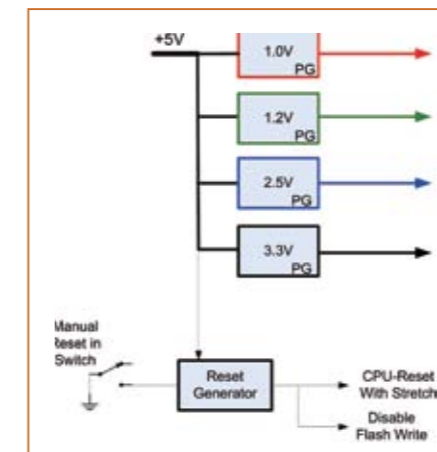

Figure 3: Monitoring just the input voltage.

specification is $1V \pm 5\%$. The supervisor monitoring threshold should be set to $1V-5\% = 0.95V$. With this setting, the supervisor IC generates a low voltage interrupt when the VCC-CPU Core is less than $0.95V$. The supervisor IC in Figure 1 activates the CPU interrupt signal when any of the 5 monitored supplies drop below their corresponding voltage threshold levels.

Voltage supervisor accuracy

For the supervisor in Figure 1, a $0.95V$ threshold accuracy of 2% means that the CPU interrupt signal can be activated anywhere from $0.95V+2\%$ to $0.95V-3\%$ ($\sim 0.97V$ to $0.93V$). Using this supervisor IC, the supervisor threshold should be set at $0.97V$ to prevent the processor from operating at a voltage less than its tolerance level. However, this setting restricts the DC-DC converter tolerance. In general, supervisors with an accuracy of around 1% provide the optimal solution.

Supervisor fault detection delay

Fault detection delay is measured from the time the power supply voltage drops below the threshold of the supervisor to the time the output of the supervisor toggles to indicate the fault. However, the supply voltage continues to drop during the fault detection delay. The longer the delay, the lower the power supply voltage will be at the time of fault reporting. Consequently, the fault detection delay should be as short as possible (optimally, in the tens of microseconds).

The following section examines sev-

eral Voltage Supervision and Reset Generation circuits as well as their advantages and disadvantages.

Monitoring power supply voltages using power good signals

The PG (Power Good) signal of a DC-DC Converter indicates that the supply has reached approximately 90% of its rated voltage. In the circuit shown in Figure 2, all of the PG signals, as well as the manual reset signal, are connected to the PLD (Programmable Logic Device). The PLD generates the CPU reset, interrupt to CPU and the disable Flash write signal through logic equations. This arrangement is also used frequently to implement power supply sequencing.

Advantages: the PLD provides flexibility for the generation of Reset, Interrupt and Disable Flash write signals and it enables efficient implementation of sequencing of supplies. Because this circuit is independent of the output voltage of the DC-DC Converters, it can be used as a standard solution across many applications.

Disadvantage: inaccuracy of voltage monitoring. The threshold accuracy of the PG circuitry in most DC-DC Converters is between 5% and 10%. With this margin of error, it is impossible to monitor a supply voltage variation of 5%.

Additionally, this method does not monitor the input voltage; consequently, it does not provide sufficient time for the microprocessor during the board turn off process.

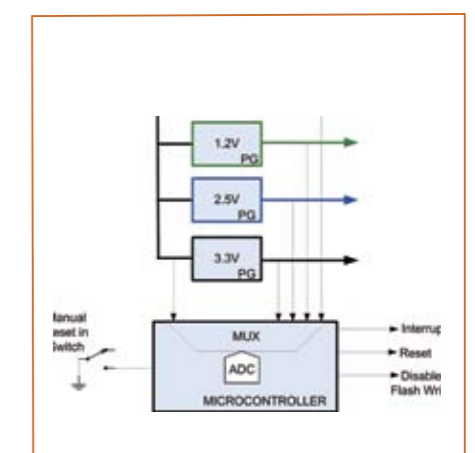

Figure 4: Monitoring voltage using a microcontroller.

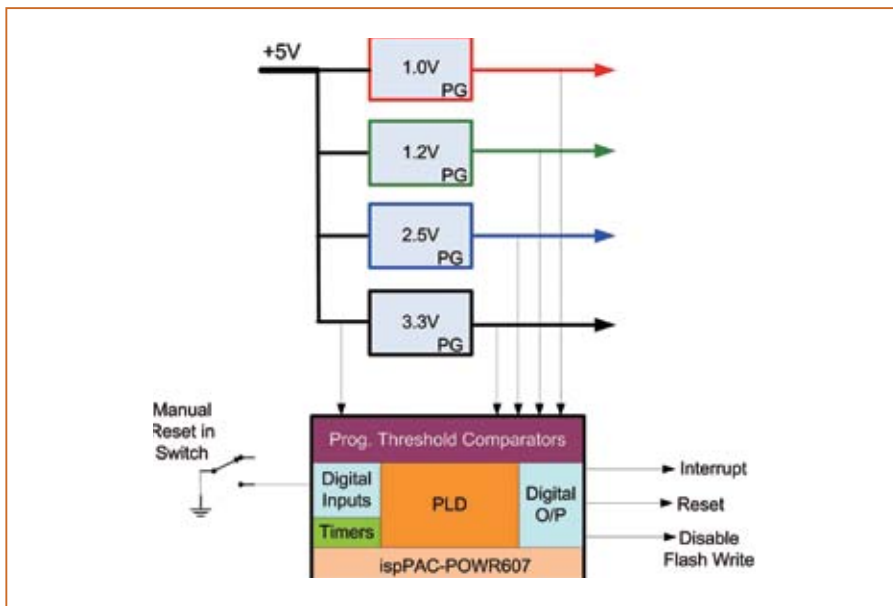

Figure 5: Voltage monitoring using a programmable power manager IC.

Monitoring only the input supply

The monitoring circuit in Figure 3 uses a low cost reset generator to monitor just the input voltage. None of the on-board DC-DC Converters are monitored.

The advantage of this method is that it provides a low cost solution for voltage monitoring and takes care of reset generation during power turn off and turn on.

The disadvantage of this method is that it has no way to determine whether the remaining supplies on the board are operating properly. Therefore, it cannot prevent errors such as Flash data corruption due to the failure of any of the on-board DC-DC converters.

Monitoring supplies using a microcontroller with ADC

The circuit in Figure 4 uses a low cost microcontroller with an integrated Analog to Digital Converter (ADC) for supervision and reset generation. The voltage monitoring software code in the microcontroller measures each of the supply voltages using the on-board ADC in a round robin format, compares the digital code with an internally stored voltage threshold, and determines if there is a power supply error. The voltage monitoring software usually is invoked by an interrupt once every 5 to 10 ms.

The advantage of this method is that it provides flexibility and enables set-

ting the voltage monitoring thresholds with fine granularity (limited only by the ADC resolution). Additionally, the same arrangement can be used as a standard across various designs because it allows board specific customization through software.

The disadvantage of this method is that: the fault detection is too slow and usually needs an external band-gap reference to meet the accuracy requirements.

Major delay in the fault detection is due to the invocation of the monitoring routine: 5 ms to 10 ms. The monitoring software routine also adds to this delay due to sequential monitoring as well as averaging requirements. When most DC-DC converters become faulty or when the supply is turned off, their voltage decays below acceptable levels in about 2 to 5 ms. A fault detection delay of 5 to 10 ms is either too late or provides only an extremely short duration for the processor to safely shut down.

In most microcontrollers, the on-chip voltage reference, which is used by the ADC to monitor voltages, has a margin of error of 2 to 4 %, creating the need for an external voltage reference IC to increase the monitoring accuracy to around 1%.

Example of a supervisor and reset generation circuit

Figure 5 shows a programmable Power Manager device, in this case the Lattice POWR607, monitoring both the input and the on-board generated voltages. The POWR607 supports the monitoring of up to 6 supply rails using the on-chip programmable threshold comparators with a fault detection delay of 12 microseconds. Typical voltage threshold accuracy is 0.5%. The outputs of the comparators are connected to the on-chip PLD. Customized control signals can be generated using logic equations implemented in the PLD. The programmable timers enable the generation of a pulse stretched Reset signal. The POWR607 IC is in-system programmable and the configuration is stored in its on-chip E2CMOS memory.

Advantages of the supervisor and reset generation circuit example

This design monitors both on-board supply voltages and the input supply, combining the advantages of the circuits in Figures 2 and 3. The programmable threshold capability provides the advantages of the circuit shown in Figure 4 that uses the microcontroller. Because the typical threshold accuracy is 0.5%, this circuit does not have the disadvantages of the circuits in Figures 2 and 4. The on-chip PLD provides the same supply sequencing flexibility as that of the circuit in Figure 2.

Evaluating the various circuits, it is clear that the circuit in Figure 5 using the Lattice Power Management IC provides the most reliable supervisor and reset generation circuit.

www.latticesemi.com